

Motorcycle Batteries

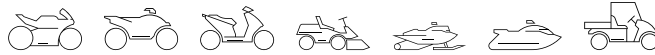

intAct Bike-Power GEL

Sealed maintenance-free GEL battery | electrolyte immobilized by gel-additive | wet charged



FOR HEAVY LOADS, INCLUDING ABS

Delivers 30% more starting power for modern motorcycles with many electrical consumers and covers consumption peaks. Low self-discharge, bike starts reliably even after up to 3 months. Our recommendation if many consumers are installed or the motorcycle is rarely used.

- » **Even more cycle-resistant** than Bike-Power AGM and Bike-Power SLA of the same box size.
- » **Low self-discharge.** For seasonal use.
- » **Very high vibration-resistance.** Electrolyte immobilized by gel-additive.
- » **30% more starting power** than a conventional battery of the same box size. For motorcycles with many consumers, including ABS.
- » **Sealed maintenance-free** battery. Refilling is neither possible nor necessary.
- » Wet charged. **Ready to use.**

Datasheet

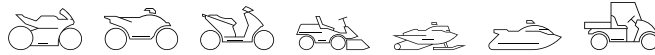

| | |
|---------------------|--------------------------|
| Artnum. | IG YTX9-BS |
| Japan-Code | CTX9-BS, 50812 |
| Volt | 12V |
| Capacity | 8 AH (c20) |
| CCR - 18°C (EN) | 170 A (EN) |
| Electrolyte | diluted sulphuric acid |
| Electrolyte density | 1,28 +/- 0,01 kg/l (25°) |
| Size (LxWxH) | 150 x 87 x 105 mm |
| Weight | 3,3 kg |
| Pos. of Terminal | 1 |

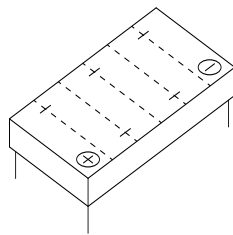
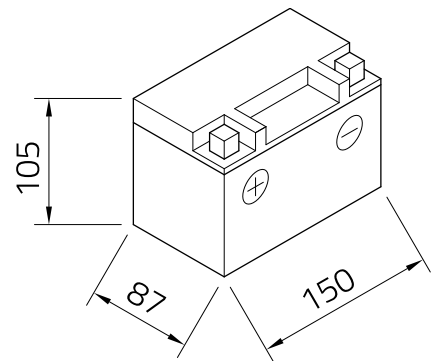

Technology Sealed maintenance-free GEL battery | electrolyte immobilized by gel-additive | wet charged

Terminal A

Base plate -