

# Motorcycle Batteries

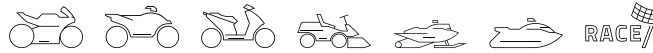

## intAct Bike-Power HVT

Sealed maintenance-free AGM battery with heavily compressed plate packs | electrolyte held in glass fibre separators



## EXTREMELY VIBRATION-RESISTANT DESIGN

The durable energy bundle absorbs the strongest shocks from Harleys and other high-capacity bikes and also starts two-wheelers with high electrical energy requirements (e.g. with ABS). Our recommendation for motorcycles that need a lot of starting power and of course with strong vibrations.

- » Perfect for **Harleys** and other bikes with **high-capacity 2-cylinder engines**.
- » **Highest cold cranking amper:** For two-wheelers with high energy requirements, e.g. due to ABS safety technology.
- » **Extremely vibration-resistant.** Plate packs compressed and precisely fitted into the battery box.
- » **Robust housing made of impact-resistant plastic.** For heavy mechanical stress.
- » **Leak-proof.** Can be installed **at an angle**, as the electrolyte is held in glass fibre mat.
- » **Sealed maintenance-free.**

# Datasheet



Artnum.	IH HVT-01
Japan-Code	CTX20L-BS, 65989-97A
Volt	12V
Capacity	20 AH (c20)
CCR - 18°C (EN)	350 A (EN)
Electrolyte	diluted sulphuric acid
Electrolyte density	1,32 +/- 0,01Kg/l (25°)
Size (LxWxH)	175 x 87 x 155 mm
Weight	6,5 kg
Pos. of Terminal	0

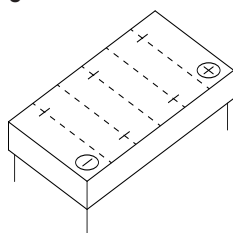
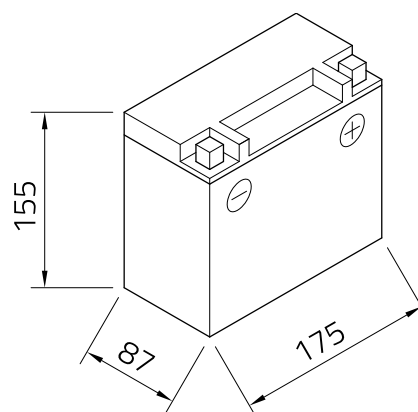

**Technology** Sealed maintenance-free AGM battery with heavily compressed plate packs | electrolyte held in glass fibre separators

**Terminal** M

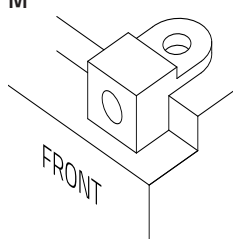

**Base plate** -