

Motorcycle Batteries

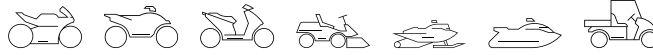

intAct Bike-Power SLA

Sealed maintenance-free AGM battery (electrolyte held in Absorbent Glass Mat separators) | wet charged



READY-TO-USE ALL-ROUNDER

Withstands the frequent charging cycles in seasonal use and on many short trips slightly better than conventional flooded batteries and starts reliably even when not fully charged. Our recommendation for an inexpensive absolutely maintenance-free battery.

- » **High power reserve.** Significant starting power even when partially discharged.
- » **Shake-proof.** The plates are firmly embedded in the glass fibre mat.
- » **Sealed maintenance-free** with gas recombination, where refilling is neither possible nor necessary.
- » **Leak-proof.** The battery can be installed at an angle, as the electrolyte is held in a glass fibre mat and the battery is factory sealed.
- » Wet charged. **Ready to use.**

Datasheet



Artnum. IS YTZ10-S

Japan-Code CTZ10-S

Volt 12V

Capacity 8,5 AH (c20)

CCR - 18°C (EN) 140 A (EN)

Electrolyte diluted sulphuric acid

Electrolyte density 1,32 +/- 0,01 kg/l (25°)

Size (LxWxH) 150 x 87 x 94 mm

Weight 3,1 kg

Pos. of Terminal 1

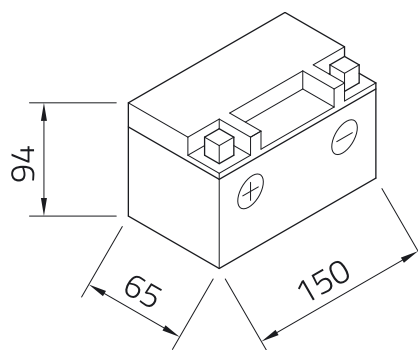
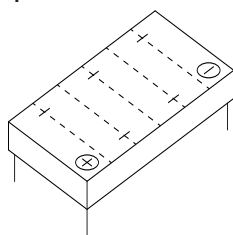

Technology Sealed maintenance-free AGM battery (electrolyte held in Absorbent Glass Mat separators) | wet charged

Terminal A

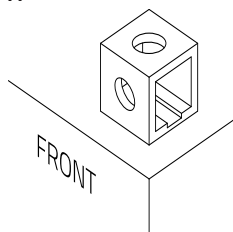

Base plate -