



intAct Bike-Power AGM

Sealed AGM battery (electrolyte absorbed in glass fibre mats) | dry-charged, acid pack is included | maintenance-free after initial filling



intAct Bike-Power AGM

Affordable all-rounder

Acid packs may not be delivered to private customers

According to the EU Regulation 2019/1148, acid packs may no longer be delivered to end customers as of 1.2.2021.

Withstands the frequent charging cycles in seasonal use and on many short trips slightly better than conventional flooded batteries and starts reliably even when not fully charged.

Our recommendation for anybody in need of an affordable sealed motorcycle battery.

CHARACTERISTICS

High power reserve. Significant starting power even when partially discharged.

Shake-proof. The plates are firmly embedded in the glass fibre mat.

Maintenance-free after initial filling by a specialist dealer or workshop.

Refilling is then no longer possible and not necessary, because the then sealed battery loses virtually no liquid due to gas recombination.

Not well suited for repeated deep discharging (below 10.5 volts).

The battery can also be installed at an angle, as the electrolyte is absorbed in the glass fiber mat and the battery is tightly sealed after filling.

LANDPORT
BATTERIES

Ramgatseweg 63 // NL - 4941 VN Raamsdonksveer
Phone: +31 (0) 162 58 14 00 // Fax: +31 (0) 162 58 14 01
info@landportbv.com // www.landportbv.com

intAct
BATTERY - POWER

ALWAYS THE
BATTERY
THAT FITS!

intAct Bike-Power AGM

Sealed AGM battery (electrolyte absorbed in glass fibre mats) | dry-charged,
acid pack is included | maintenance-free after initial filling

Item Nr.	Volt	Capacity	Cold cranking ampere	Length mm	Width mm	Height mm	Position of terminal	Terminal	Base plate	Weight/ kg
IA CB5L-B	12	5 Ah (C20)	70 A (EN)	120	61	127	0	A	–	1.85
IA CIX30L-BS	12	30 Ah (C20)	350 A (EN)	166	126	175	0	A	–	9.3
IA CT12B-BS	12	10 Ah (C20)	130 A (EN)	150	70	130	1	A	–	3.39
IA CT14B-BS	12	12 Ah (C20)	140 A (EN)	150	70	145	1	A	–	3.95
IA CT7B-BS	12	6.5 Ah (C20)	80 A (EN)	150	66	93	1	A	–	2.17
IA CT9B-BS	12	8 Ah (C20)	120 A (EN)	150	70	105	1	A	–	2.65
IA CTR4A-BS	12	2.5 Ah (C20)	50 A (EN)	113	48	85	4	L	–	0.99
IA CTX12A-BS	12	10 Ah (C20)	130 A (EN)	150	88	105	1	J	–	3.29
IA CTX12-BS	12	10 Ah (C20)	130 A (EN)	150	87	130	1	A	–	3.58
IA CTX14AH-BS	12	12 Ah (C20)	140 A (EN)	133	90	164	1	A	–	4.24
IA CTX14AHL-BS	12	12 Ah (C20)	140 A (EN)	133	90	164	0	A	–	4.24
IA CTX14-BS	12	12 Ah (C20)	140 A (EN)	150	87	145	1	A	–	4.06
IA CTX14L-BS	12	12 Ah (C20)	140 A (EN)	150	87	145	0	A	–	4.06
IA CTX16-BS	12	14 Ah (C20)	220 A (EN)	150	87	161	1	A	–	4.99
IA CTX20-BS	12	18 Ah (C20)	280 A (EN)	175	87	155	1	A	–	5.62
IA CTX20CH-BS	12	18 Ah (C20)	280 A (EN)	150	87	161	1	J	–	5.18
IA CTX20HL-BS	12	20 Ah (C20)	310 A (EN)	175	87	155	0	A	–	5.95
IA CTX20L-BS	12	18 Ah (C20)	280 A (EN)	175	87	155	0	A	–	5.63
IA CTX24HL-BS	12	21 Ah (C20)	350 A (EN)	205	87	162	0	A	–	6.99
IA CTX4L-BS	12	3 Ah (C20)	50 A (EN)	113	70	85	0	A	–	1.32
IA CTX5L-BS	12	4 Ah (C20)	50 A (EN)	113	70	105	0	A	–	1.67
IA CTX7A-BS	12	6 Ah (C20)	80 A (EN)	150	87	93	1	A	–	2.35
IA CTX7L-BS	12	6 Ah (C20)	80 A (EN)	113	70	130	0	A	–	2.17
IA CTX9A-BS	12	9 Ah (C20)	120 A (EN)	135	75	139	1	A	–	3.11
IA CTX9-BS	12	8 Ah (C20)	120 A (EN)	150	87	105	1	A	–	2.85
IA CTZ10S-BS	12	8.5 Ah (C20)	120 A (EN)	150	88	93	1	A	–	3.11
IA CTZ12S-BS	12	11 Ah (C20)	130 A (EN)	150	88	110	1	A	–	3.79
IA CTZ14S-BS	12	11.5 Ah (C20)	140 A (EN)	150	88	110	1	A	–	3.85
IA CTZ7S-BS	12	6 Ah (C20)	80 A (EN)	113	70	105	0	A	–	2.17

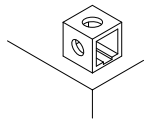
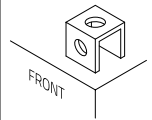
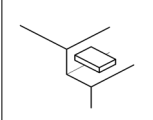
TERMINAL		
Terminal: A	Terminal: J	Terminal: L
		

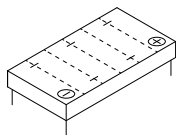
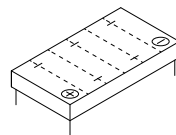
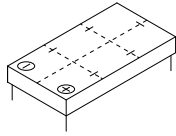
POSITION OF TERMINAL			
12 Volt 0		12 Volt 1	
12 Volt 4			

LANDPORT
BATTERIES

Ramgatseweg 63 // NL - 4941 VN Raamsdonksveer
 Phone: +31 (0) 162 58 14 00 // Fax: +31 (0) 162 58 14 01
 info@landportbv.com // www.landportbv.com

intAct
BATTERY - POWER

ALWAYS THE
BATTERY
THAT FITS!