

L60-N30L-A (12V 30Ah)



Item Code: MD L60-N30L-A
EAN: 8717101016701

Features

- ⚡ Conventional battery
- ⚡ Robust technology
- ⚡ Reliable starting battery
- ⚡ OEM Quality
- ⚡ Supplies with acid pack



Specifications

Nominal Voltage	12V
Cold Cranking Ampere (CCA)	300A
Nominal Capacity	30Ah
Container Material	ABS
Approx. Weight	8.41 kg (18.5lbs)
Acid Weight	2.46 kg (5.42lbs)
Layout	18
Terminal	D
Dimensions	Length 184 mm
	Width 130 mm
	Height 170 mm
	Total Height 170 mm

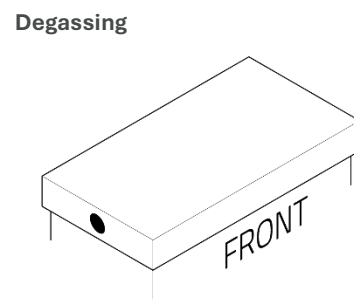
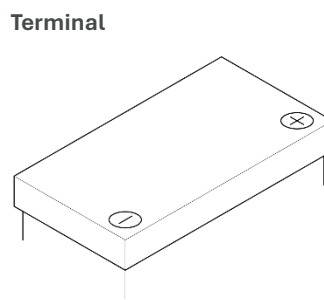
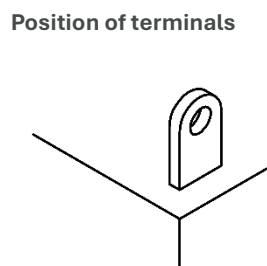
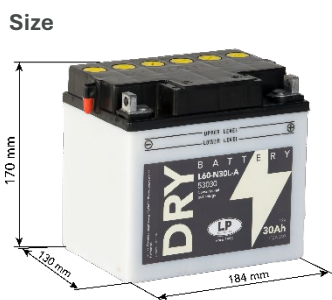

Alternatives

LP Batteries

Technology	Art. number
LFP	ML LFP30
GEL	MG L60-N30-3
SLA	MS L60-N30-3
DRY	-

Other Brands

IG C60-N30L-A - IL LFP30

(Note) All above information shall be changed without prior notice, Landport Batteries reserves the right to explain and update the latest information.