

# LB16B-A1 (12V 16Ah)



Item Code: MD LB16B-A1  
 EAN: 8717101016749

## Features

- ⚡ Conventional battery
- ⚡ Robust technology
- ⚡ Reliable starting battery
- ⚡ OEM Quality
- ⚡ Supplies with acid pack



## Specifications

Nominal Voltage	12V
Cold Cranking Ampere (CCA)	175A
Nominal Capacity	16Ah
Container Material	ABS
Approx. Weight	5.24 kg (11.60lbs)
Acid Weight	1.41 kg (3.11lbs)
Layout	7
Terminal	H
Dimensions	
	Length 160 mm
	Width 90 mm
	Height 161 mm
	Total Height 161 mm

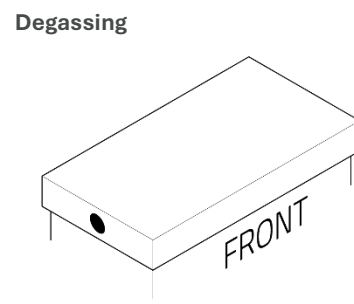
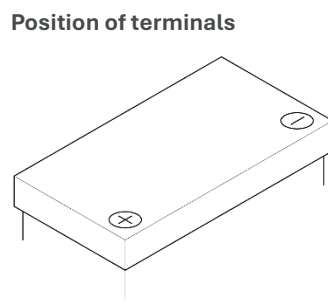
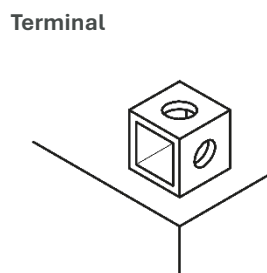
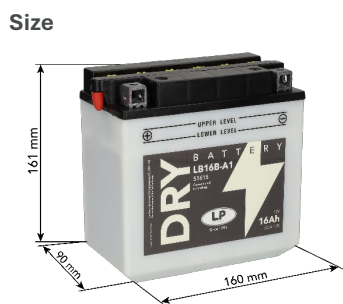

## Alternatives

### LP Batteries

Technology	Art. number
LFP	ML LFP14
GEL	-
SLA	-
AGM	MA LTX16-BS-1

### Other Brands

IA CTX16-BS-1 - IL LFP14

(Note) All above information shall be changed without prior notice, Landport Batteries reserves the right to explain and update the latest information.