

# LB16L-B (12V 19Ah)



Item Code: MD LB16L-B  
 EAN: 8717101015728

## Features

- ⚡ Conventional battery
- ⚡ Robust technology
- ⚡ Reliable starting battery
- ⚡ OEM Quality
- ⚡ Supplies with acid pack



## Specifications

Nominal Voltage	12V
Cold Cranking Ampere (CCA)	220A
Nominal Capacity	19Ah
Container Material	ABS
Approx. Weight	6.06 kg (13.4lbs)
Acid Weight	1.63 kg (3.59lbs)
Layout	15
Terminal	B
Dimensions	Length 175 mm
	Width 100 mm
	Height 155 mm
	Total Height 155 mm

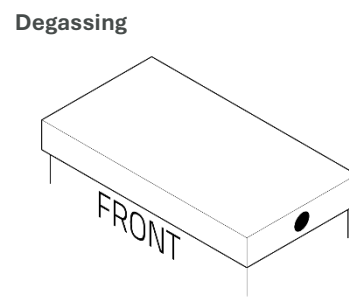
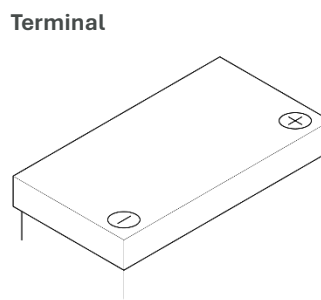
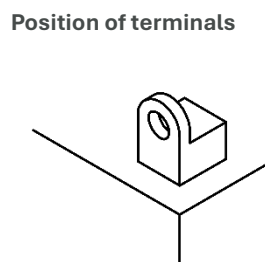

## Alternatives

### LP Batteries

Technology	Art. number
LFP	ML LFP16
GEL	-
HVT	MH HVT-4
AGM	-

### Other Brands

IG CB16L-B - IL LFP16

(Note) All above information shall be changed without prior notice, Landport Batteries reserves the right to explain and update the latest information.